

BUIZEN - ROND
 TUYAUX - ROND
 PIPES - ROUND

L = 5 m

Zelfdovend en elektrisch geleidend
 Auto-extinguible et conducteur d'électricité.
 Self-extinguishing and electro-conductive.

D x s	KG/M	€/M
50 x 4.6	0.79	34.08
63 x 5.8	1.20	53.92
75 x 6.8	1.70	75.21
90 x 8.2	0.93	39.01
110 x 3.0	1.24	54.06
160 x 3.0	1.82	79.34
180 x 3.0	2.05	89.33
200 x 3.0	2.28	99.39
225 x 3.5	2.57	129.87
250 x 3.5	3.50	150.84
315 x 5.0	5.80	253.23
355 x 5.0	6.60	275.01
400 x 6.0	8.94	372.53

Grotere diameters : op aanvraag
 Diamètres plus larges: sur demande
 Larger diameters: on request

Fire class: V-0, US standard UL94

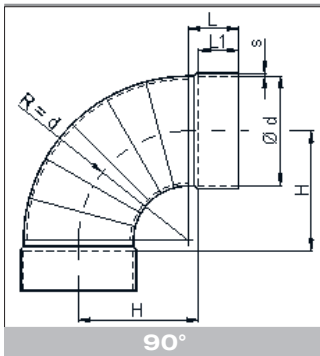

BOCHTEN R = 1D
 COURBES R = 1D
 BENDS R = 1D

SEGMENTVRIJ
 SANS SEGMENTS
 WITHOUT SEGMENTS

Beide zijden gemoft.
 Manchonnées des deux côtes.
 Welding sleeves on both ends.

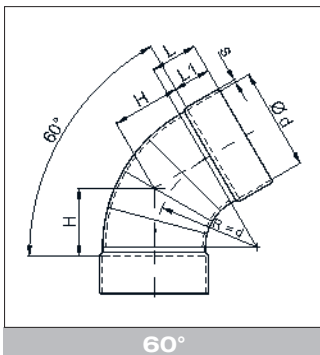
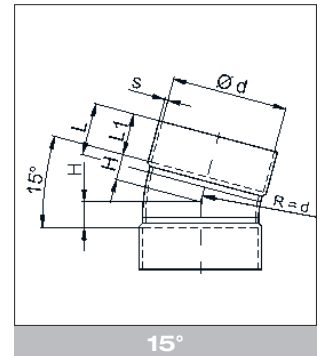
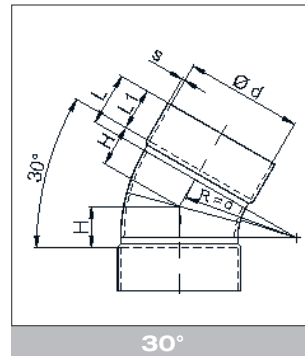
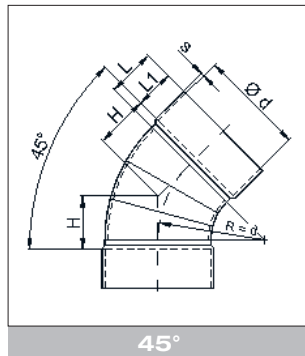
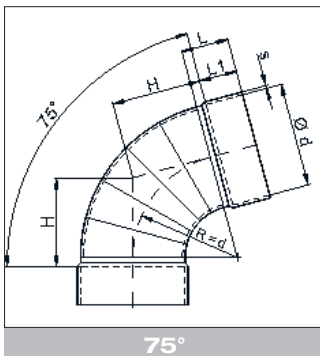

d	L	L1	s	H						€/ST/PC					
				90°	75°	60°	45°	30°	15°	90° GBM	75° LBM	60° KBM	45° HBM	30° IBM	15° JBM
50	30	25	3.0	55	45	35	30	20	10	38.54	38.54	38.54	29.98	29.98	29.98
63	30	25	3.0	70	55	40	32	20	15	38.54	38.54	38.54	29.98	29.98	29.98
75	40	35	3.0	80	65	50	35	25	15	38.54	38.54	38.54	29.98	27.84	27.84
90	40	35	3.0	95	75	55	40	30	15	40.68	40.68	40.68	33.19	29.98	29.98
110	50	40	3.0	120	95	75	55	40	15	46.04	46.04	46.04	35.33	29.98	29.98
125	50	40	3.0	135	105	80	60	45	25	53.53	53.53	53.53	41.75	33.19	33.19
140	50	40	3.0	150	115	90	70	50	30	64.24	64.24	64.24	54.60	49.25	49.25
160	50	40	3.0	170	135	100	75	55	20	66.38	66.38	66.38	64.24	54.60	54.60
180	60	50	3.0	190	150	115	85	60	35	74.94	74.94	74.94	71.73	59.95	59.95
200	60	50	3.0	210	165	125	95	65	25	83.51	83.51	83.51	72.80	69.59	69.59
225	60	50	3.5	235	185	140	105	70	40	105.99	105.99	105.99	93.14	77.08	77.08
250	60	50	3.5	260	200	155	115	75	35	124.19	124.19	124.19	98.50	83.51	83.50
280	60	50	4.0	290	225	170	125	85	45	258.01	258.01	258.01	229.11	118.84	118.84
315	60	50	5.0	325	250	190	140	95	50	276.21	276.21	276.21	270.86	229.11	229.11
355	60	50	5.0	365	280	215	160	105	55	574.24	574.24	574.24	325.39	399.01	399.01
400	70	60	6.0	410	320	245	175	120	70	809.81	809.81	809.81	482.94	556.56	556.56
450	70	60	6.0	460	360	275	200	135	75	1831.80	1831.80	1337.18	1337.18	1337.18	1337.18
500	70	60	6.0	510	405	310	215	155	85	1973.12	1973.12	1430.32	1430.32	1430.32	1430.32
560	110	90	6.0	580	450	345	250	170	95	2017.01	2017.01	1585.56	1585.56	1585.56	1585.56
630	110	90	8.0	650	485	385	280	190	100	2331.77	2331.77	1846.79	1846.79	1846.79	1846.79
710	110	90	8.0	730	565	430	310	210	115	2880.98	2880.98	2493.43	2493.43	2493.43	2493.43
800	120	100	10.0	820	630	480	350	235	125	3761.02	3761.02	2935.59	2935.59	2935.59	2935.59
900	130	110	8.0	1030	795	605	410	265	160	5663.07	5663.07	4981.32	4212.71	4212.71	4212.71
1000	130	110	8.0	1030	795	605	410	265	160	6546.82	6546.82	5763.06	5058.08	5058.08	5058.08

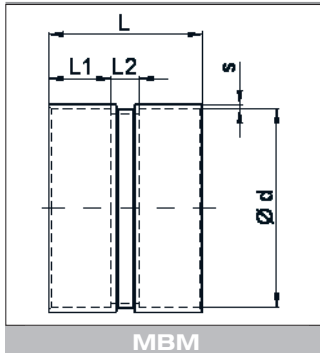
**SOKKEN
 MANCHONS
 SOCKETS**

d	L	L1	L2	S	KG/ST/PC	€/ST/PC
50	80	25	30	3.0	0.1	25.69
63	80	25	30	3.0	0.1	25.69
75	100	35	30	3.0	0.1	25.69
90	100	35	30	3.0	0.1	25.69
110	100	40	20	3.0	0.1	25.69
125	100	40	20	3.0	0.1	29.98
140	100	40	20	3.0	0.2	31.05
160	100	40	20	3.0	0.2	33.19
180	100	40	20	3.0	0.2	36.40
200	120	50	20	3.0	0.2	38.54
225	120	50	20	3.5	0.3	46.04
250	120	50	20	3.5	0.4	54.60
280	120	50	20	4.0	0.4	59.95
315	120	50	20	5.0	0.8	64.24
355	135	50	35	5.0	0.9	283.71
400	155	60	35	6.0	1.0	323.32
450	160	60	40	6.0	1.2	443.52
500	160	60	40	6.0	1.0	499.97
560	170	70	30	6.0	2.0	661.63
630	170	70	30	8.0	2.2	758.98

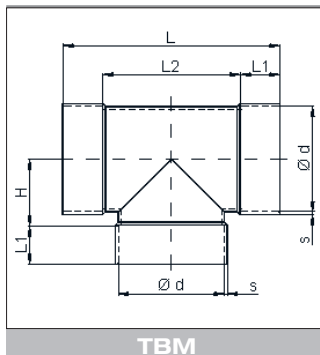
**T-STUKKEN 90°
 TES A 90°
 TEES 90°**

Driezijdig gemoft. Reductie T-stukken eveneens leverbaar.
 Manchonnées des trois côtés. Tés réduits aussi livrables.
 Welding sleeves on all ends. Reducing tees also available.

d	L	L1	L2	H	S	KG/ST/PC	€/ST/PC
50	140	35	70	35	3.0	0.1	89.89
63	1160	35	90	45	3.0	0.2	107.70
75	170	35	100	55	3.0	0.2	118.74
90	200	35	130	60	3.0	0.2	143.99
110	225	40	145	70	3.0	0.3	196.99
125	285	50	185	85	3.0	0.4	221.61
140	295	45	205	95	3.0	0.5	247.31
160	330	40	250	100	3.0	0.6	258.01
180	380	55	270	110	3.0	1.0	301.91
200	385	50	285	120	3.0	1.2	320.11
225	455	60	335	140	3.5	1.4	381.13
250	415	50	315	145	3.5	1.6	430.38
280	465	50	365	175	4.0	1.7	518.17
315	530	60	410	190	5.0	3.3	604.89
355	595	50	495	225	5.0	3.4	1190.51
400	610	60	490	240	6.0	5.1	1414.26
*450	700	70	560	250	6.0	7.0	1758.38
*500	780	70	640	305	6.0	8.0	1858.28
*560	840	70	700	350	6.0	10.0	2416.49
*630	910	70	770	390	6.0	12.0	2609.40
*710	950	80	790	490	8.0	29.0	3691.91
*800	1040	80	880	440	8.0	34.0	4752.28

* gesegmenteerd / segmenté / segmented

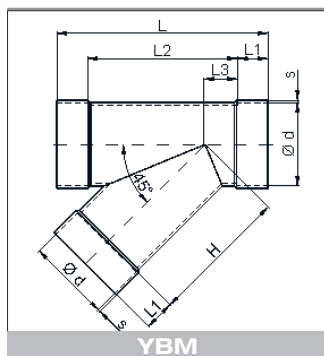

T-STUKKEN 45°
 TES A 45°
 TEES 45°

Driezijdig gefoet.
 Manchonnées des trois côtés.
 Welding sleeves on all ends.

d	L	L1	L2	L3	H	S	KG/ST/PC	€/ST/PC
50	170	35	100	25	75	3.0	0.2	202.48
63	190	35	120	28	95	3.0	0.2	214.01
75	215	40	135	30	105	3.0	0.3	229.07
90	240	40	160	35	125	3.0	0.4	262.30
110	290	40	210	50	160	3.0	0.5	262.30
125	290	40	210	42	167	3.0	0.7	279.43
140	325	45	235	48	188	3.0	0.9	323.32
160	395	55	285	63	222	3.0	1.3	364.00
180	420	50	320	70	250	3.0	1.4	398.26
200	435	45	345	72	272	3.0	1.5	459.29
225	490	50	390	82	307	3.5	2.1	511.75
250	500	40	420	85	335	3.5	2.6	604.89
280	570	50	470	95	375	4.0	3.0	677.69
315	640	60	520	102	417	5.0	3.8	837.21
355	675	50	575	110	465	5.0	4.5	1244.04
400	780	60	660	130	539	6.0	9.9	1454.95
*450	925	65	795	172	622	6.0	11.0	2146.55
*500	995	65	865	182	682	6.0	13.0	2459.08

* gesegmenteerd / segmenté / segmented

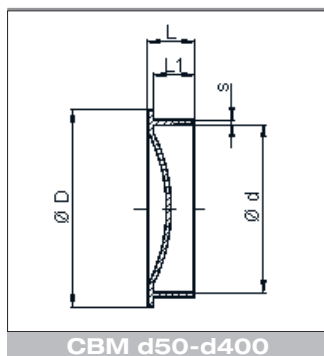

CBM d50-d400

AFSLUITKAPPEN
 BOUCHONS
 END CAPS

d	D'	L	L1	S	KG/ST/PC	€/ST/PC
50	65	25	22	3.0	0.1	31.98
63	80	25	22	3.0	0.1	35.43
75	90	25	22	3.0	0.1	38.54
90	105	25	22	3.0	0.1	38.54
110	140	27	24	3.5	0.1	40.68
125	155	28	23	3.5	0.1	40.68
140	170	28	25	3.5	0.1	51.39
160	190	28	25	3.5	0.2	54.60
180	210	28	24	3.5	0.2	59.95
200	230	28	24	3.5	0.2	66.38
225	255	28	25	4.0	0.3	78.15
250	280	28	25	4.0	0.4	89.93
280	312	28	25	4.0	0.4	100.64
315	352	28	24	4.0	0.6	111.34
355	390	28	23	4.0	0.7	131.65
400	432	29	25	6.0	0.9	145.17
450	480	76	70	6.0	1.6	301.88
500	530	76	70	6.0	1.8	327.10
560	590	76	70	6.0	2.5	745.48
630	660	76	70	6.0	3.0	775.95

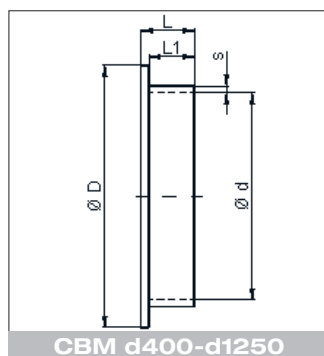

CBM d400-d1250

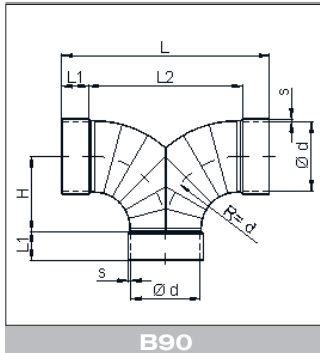
B90

BROEKSTUKKEN 90° R=1D
 CULOTTES A 90° R=1D
 Y-PIECES 90° R=1D

Driezijdig gemoft.
 Manchonnées des trois côtés.
 Welding sleeves on all ends.

d	L	L1	L2	H	S	KG/ST/PC	€/ST/PC
50	170	30	110	55	3.0	0.2	147.74
63	200	30	140	70	3.0	0.2	162.73
75	230	35	160	80	3.0	0.2	180.93
90	260	35	190	95	3.0	0.3	192.71
110	320	40	240	120	3.0	0.4	218.40
125	350	40	270	135	3.0	0.6	245.17
140	380	40	300	150	3.0	0.7	279.43
160	420	40	340	170	3.0	0.8	320.11
180	480	50	380	190	3.0	1.0	388.63
200	520	50	420	210	3.0	1.4	422.89
225	570	50	470	235	3.5	1.8	570.63
250	620	50	520	260	4.0	2.3	642.36
280	680	50	580	290	4.0	4.2	922.86
315	750	50	650	325	5.0	4.8	1004.22
355	830	50	730	365	5.0	6.2	1307.20
400	920	50	820	410	6.0	7.7	1400.63

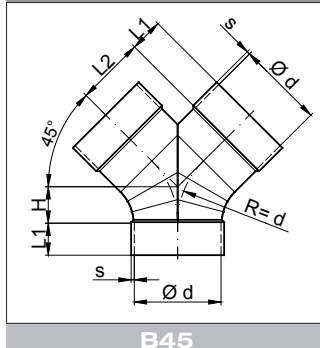

B45

BROEKSTUKKEN 45° R=1D
 CULOTTES A 45° R=1D
 Y-PIECES 45° R=1D

Driezijdig gemoft.
 Manchonnées des trois côtés.
 Welding sleeves on all ends.

d	L1	L2	H	S	KG/ST/PC
50	30	50	25	3.0	0.1
63	30	55	30	3.0	0.1
75	35	65	35	3.0	0.2
90	35	70	40	3.0	0.2
110	40	95	45	3.0	0.4
125	40	100	60	3.0	0.4
140	40	120	70	3.0	0.5
160	40	140	65	3.0	0.7
180	50	150	85	3.0	1.0
200	50	175	85	3.0	1.1
225	50	185	105	3.5	1.4
250	50	215	105	3.5	1.5
280	50	245	125	4.0	2.4
315	50	275	140	5.0	3.0
355	50	305	155	5.0	4.0
400	50	355	180	6.0	6.3

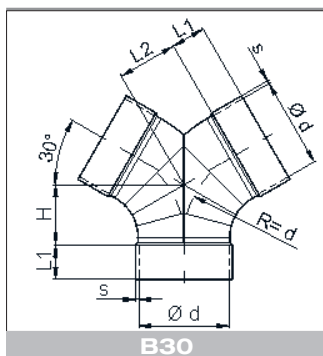
prijs op aanvraag / prix sur demande / price on request



BROEKSTUKKEN 30° R=1D
CULOTTES A 30° R=1D
Y-PIECES 30° R=1D

Driezijdig gemoft.
Manchonnées des trois côtés.
Welding sleeves on all ends.

d	L1	L2	H	S	KG/ST/PC
50	30	35	35	3.0	0.1
63	30	40	40	3.0	0.1
75	30	50	50	3.0	0.2
90	35	55	55	3.0	0.2
110	40	75	75	3.0	0.3
125	40	80	80	3.0	0.4
140	40	90	90	3.0	0.5
160	40	100	100	3.0	0.6
180	50	115	115	3.0	0.9
200	50	125	125	3.0	1.0
225	50	140	140	3.5	1.3
250	50	155	155	3.5	1.4
280	50	170	170	4.0	2.2
315	50	190	190	5.0	2.6
355	50	215	215	5.0	3.6
400	50	245	245	6.0	4.8

prijs op aanvraag / prix sur demande / price on request

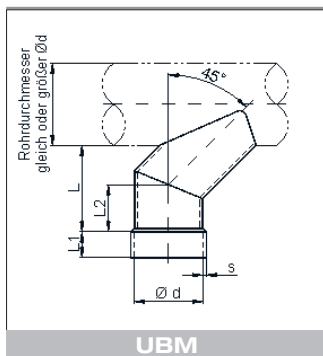

ZADELSTUKKEN 90°
PIEDS DE BICHE A 90°
SADDLE CONNECTIONS 90°

d	L	L1	L2	S	KG/ST/PC	€/ST/PC
50	65	35	30	3.0	0.1	124.19
63	80	35	33	3.0	0.1	124.19
75	90	35	36	3.0	0.1	124.19
90	100	35	39	3.0	0.2	127.40
110	130	40	53	3.0	0.3	137.04
125	145	40	56	3.0	0.3	155.24
140	160	40	59	3.0	0.4	184.14
160	185	40	73	3.0	0.5	223.76
180	205	50	77	3.0	0.6	249.45
200	225	50	81	3.0	0.8	270.86
225	255	50	97	3.5	1.1	323.32
250	280	50	102	3.5	1.3	344.73
280	305	50	108	4.0	1.9	550.29
315	340	50	115	5.0	2.8	766.55
355	375	50	124	5.0	3.5	846.39
400	415	60	133	6.0	5.3	-

Buisstuk niet inbegrepen
Pied de tube no inclusive
Pipe connection not included

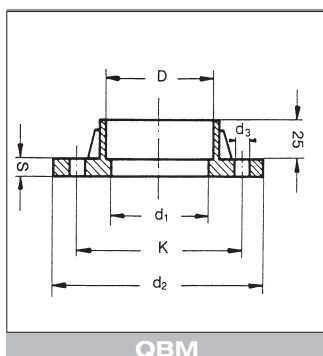
QBM

 OPLASFLENZEN
 BRIDES A SOUDER
 WELDING FLANGES

d	D	B	s	k	d1	d2	n	KG	FLENS BRIDE FLANGE €/ST/PC	DICHTING JOINT SEAL €/ST/PC EPDM
50	100	8.0	3.0	80	46	7	4	0.1	34.54	5.76
63	120	8.0	3.0	100	59	7	4	0.1	34.54	5.76
75	135	8.0	3.0	115	71	7	4	0.1	34.54	5.76
90	150	8.0	3.0	130	86	7	4	0.1	36.36	5.96
110	170	8.0	4.0	150	106	7	4	0.2	38.44	6.55
125	185	8.0	4.0	165	121	7	8	0.2	40.38	7.35
140	200	8.0	4.0	175	136	7	8	0.2	44.09	7.94
160	230	8.0	4.0	200	156	7	8	0.2	46.07	8.94
180	250	8.0	4.0	225	176	7	8	0.3	55.73	10.32
200	270	8.0	4.0	240	196	7	8	0.3	57.57	11.11
225	295	8.0	4.0	265	221	7	8	0.3	59.44	12.12
250	320	10.0	4.0	290	246	7	12	0.3	65.25	12.92
280	360	10.0	4.0	325	274	9	12	0.4	72.87	14.70
315	395	10.0	4.5	350	309	9	12	0.5	74.91	16.68
355	435	10.0	6.0	400	349	9	12	0.6	146.40	19.06
400	480	10.0	6.5	445	394	9	16	0.8	167.45	21.64

Blindflens op aanvraag / bride pleine sur demande / blank flange on request

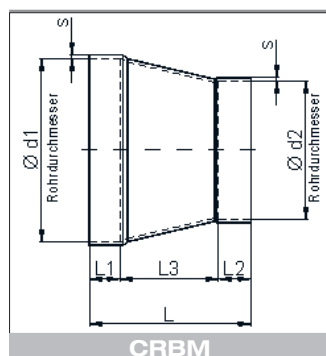
 CONCENTRISCHE REDUCTIES
 REDUCTIONS CONCENTRIQUES
 CONCENTRIC REDUCERS

Beide zijden gemoft / Manchonnées des deux côtés / Welding sleeves on both ends

d1	d2	L	L1	L2	L3	s	KG/ST/PC	€/ST/PC
63	50	83	25	35	23	3.0	0.1	130.61
75	50	115	35	35	45	3.0	0.1	130.61
75	63	105	35	25	45	3.0	0.1	132.75
90	50	145	35	35	75	3.0	0.1	148.81
90	63	130	35	25	70	3.0	0.1	148.81
90	75	110	35	35	40	3.0	0.1	111.34
110	50	170	40	35	95	3.0	0.2	111.34
110	63	170	40	25	105	3.0	0.1	114.55
110	75	170	40	35	95	3.0	0.2	66.38
110	90	140	40	35	65	3.0	0.1	66.38
125	50	215	40	35	140	3.0	0.2	150.95
125	63	205	40	25	140	3.0	0.2	150.95
125	75	195	40	35	120	3.0	0.2	148.81
125	90	165	40	35	90	3.0	0.1	150.95
125	110	120	40	35	45	3.0	0.1	78.15
140	50	240	40	35	165	3.0	0.2	*
140	63	225	40	25	160	3.0	0.2	156.31
140	75	215	40	35	140	3.0	0.2	156.31
140	90	185	40	35	110	3.0	0.2	161.66
140	110	145	40	40	65	3.0	0.2	78.15
140	125	103	40	40	23	3.0	0.2	137.04
160	50	275	40	35	200	3.5	0.3	*
160	63	260	40	25	195	3.5	0.3	150.95
160	75	250	40	35	175	3.5	0.3	153.10
160	90	220	40	35	145	3.5	0.3	153.10
160	110	190	40	35	115	3.5	0.3	74.94
160	125	145	40	40	65	3.5	0.4	171.30
160	140	135	40	40	55	3.5	0.2	167.01
180	50	330	50	35	245	3.5	0.4	164.87
180	63	320	50	25	245	3.5	0.4	*
180	75	305	50	35	220	3.5	0.3	167.01
180	90	280	50	35	195	3.5	0.3	172.37
180	110	240	50	40	150	3.5	0.4	153.10
180	125	210	50	40	120	3.5	0.4	160.59
180	140	185	50	40	95	3.5	0.3	163.80
180	160	135	50	40	45	3.5	0.2	127.40
200	50	360	50	35	275	3.0	0.3	150.95
200	63	350	50	25	275	3.0	0.3	*
200	75	340	50	35	255	3.0	0.4	150.95
200	90	310	50	35	225	3.0	0.4	153.10
200	110	300	50	40	210	3.0	0.4	103.85
200	125	245	50	40	155	3.0	0.4	179.86
200	140	220	50	40	130	3.0	0.3	182.00
200	160	195	50	50	95	3.0	0.4	91.00
200	180	145	50	50	45	3.0	0.5	129.54
225	50	405	50	35	320	3.0	0.8	*
225	63	390	50	25	315	3.0	0.8	*
225	75	380	50	35	295	3.0	0.7	
225	90	350	50	35	265	3.0	0.6	241.96
225	110	300	50	40	210	3.0	0.6	241.96
225	125	290	50	40	200	3.0	0.5	203.41
225	140	260	50	40	170	3.0	0.5	195.92
225	160	225	50	40	135	3.0	0.4	148.81
225	180	210	50	50	110	3.0	0.4	216.26
225	200	155	50	50	55	3.0	0.4	148.81

* prijs op aanvraag / prix sur demande / price on request

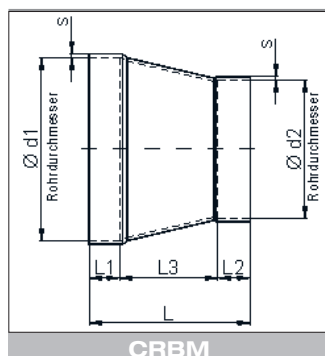
 CONCENTRISCHE REDUCTIES
 REDUCTIONS CONCENTRIQUES
 CONCENTRIC REDUCERS

D	d	L	L1	L2	L3	S	KG/ST/PC	€/ST/PC
250	50	470	50	35	385	3.5	0.8	*
250	63	455	50	25	380	3.5	0.8	*
250	75	445	50	35	360	3.5	0.7	*
250	90	415	50	35	330	3.5	0.7	154.17
250	110	345	50	40	255	3.5	0.7	156.31
250	125	340	50	40	250	3.5	0.7	158.45
250	140	305	50	40	215	3.5	0.7	166.89
250	160	285	50	40	195	3.5	0.6	88.86
250	180	265	50	50	165	3.5	0.6	203.41
250	200	215	50	50	115	3.5	0.6	129.54
250	225	165	50	50	65	3.5	0.5	190.57
280	110	400	50	40	310	3.5	1.0	210.91
280	125	390	50	40	300	3.5	1.0	210.91
280	140	360	50	40	270	3.5	1.0	221.61
280	160	335	50	50	235	3.5	1.1	236.60
280	180	295	50	50	195	3.5	1.0	232.32
280	200	260	50	50	160	3.5	0.9	236.60
280	225	260	50	50	160	3.5	0.8	226.97
280	250	210	50	50	110	3.5	0.7	178.79
315	110	470	50	40	380	4.0	1.0	317.97
315	125	460	50	40	370	4.0	1.3	332.96
315	140	435	50	40	345	4.0	1.2	334.03
315	160	395	50	40	305	4.0	1.2	241.96
315	180	360	50	40	270	4.0	0.8	289.06
315	200	330	50	50	230	4.0	1.1	265.51
315	225	285	50	50	185	4.5	1.5	265.51
315	250	240	50	50	140	4.5	0.9	165.94
315	280	190	50	50	90	4.5	0.8	203.41
355	160	470	50	50	370	5.0	1.9	362.93
355	180	435	50	50	335	5.0	1.4	370.43
355	200	400	50	50	300	5.0	1.7	270.86
355	225	350	50	50	250	5.0	1.6	283.71
355	250	305	50	50	205	4.5	1.3	226.97
355	280	250	50	50	150	5.0	1.3	263.37
355	315	200	60	50	90	5.0	1.0	223.76
400	160	575	60	50	465	5.0	2.4	398.26
400	180	540	60	50	430	5.0	2.3	398.26
400	200	500	60	50	390	5.0	2.3	404.69
400	225	455	60	50	345	5.0	2.1	315.83
400	250	415	60	50	305	5.0	2.1	309.40
400	280	345	60	50	235	5.0	1.8	309.40
400	315	290	60	50	180	5.0	1.6	315.83
400	355	225	60	50	115	5.0	1.2	270.86

* prijs op aanvraag / prix sur demande / price on request

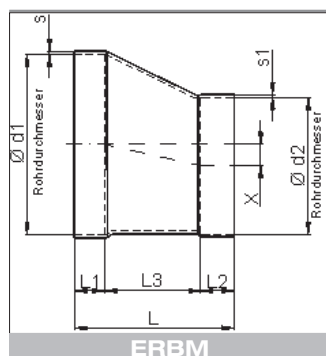

EXCENTRISCHE REDUKTIES
REDUCTIONS EXCENTRIQUES
EXCENTRIC REDUCERS

Beide zijden gemoft / Manchonnées des deux côtés / Welding sleeves on both ends

d1	d2	L	L1	L2	L3	S	S1	X	€/ST/PC
63	50	105	35	35	35	3.0	3.0	6.5	258.01
75	50	125	35	35	55	3.0	3.0	12.5	258.01
75	63	100	35	35	30	3.0	3.0	6.0	258.01
90	50	150	35	35	80	3.0	3.0	20.0	226.97
90	63	125	35	35	55	3.0	3.0	13.5	226.97
90	75	105	35	35	35	3.0	3.0	7.5	150.95
110	50	190	40	35	115	3.0	3.0	30.0	221.61
110	63	165	40	35	90	3.0	3.0	23.5	236.60
110	75	145	40	35	70	3.0	3.0	17.5	238.74
110	90	120	40	35	45	3.0	3.0	10.0	156.31
125	50	215	40	35	140	3.0	3.0	37.5	244.10
125	63	190	40	35	115	3.0	3.0	31.0	249.45
125	75	170	40	35	95	3.0	3.0	25.0	254.80
125	90	145	40	35	70	3.0	3.0	17.5	263.37
125	110	115	40	40	35	3.0	3.0	7.5	184.14
140	50	240	40	35	165	3.0	3.0	45.0	*
140	63	220	40	35	145	3.0	3.0	38.5	249.45
140	75	200	40	35	125	3.0	3.0	32.5	254.80
140	90	170	40	35	95	3.0	3.0	25.0	263.37
140	110	140	40	40	60	3.0	3.0	15.0	189.50
140	125	115	40	40	35	3.0	3.0	7.5	226.97
160	50	275	40	35	200	3.0	3.0	55.0	*
160	63	255	40	35	180	3.0	3.0	48.5	328.67
160	75	230	40	35	155	3.0	3.0	42.5	341.52
160	90	205	40	35	130	3.0	3.0	35.0	356.51
160	110	175	40	40	95	3.0	3.0	25.0	254.80
160	125	150	40	40	70	3.0	3.0	17.5	226.97
160	140	125	40	40	45	3.0	3.0	10.0	254.80
180	50	320	50	35	235	3.0	3.0	65.0	334.03
180	60	300	50	35	215	3.0	3.0	58.5	*
180	75	275	50	35	190	3.0	3.0	52.5	334.03
180	90	250	50	35	165	3.0	3.0	45.0	339.38
180	110	220	50	40	130	3.0	3.0	35.0	345.80
180	125	195	50	40	105	3.0	3.0	27.5	345.80
180	140	170	50	40	80	3.0	3.0	20.0	361.86
180	160	135	50	40	45	3.0	3.0	10.0	254.80
200	50	355	50	35	270	3.0	3.0	75.0	*
200	63	335	50	35	250	3.0	3.0	68.5	*
200	75	310	50	35	225	3.0	3.0	62.5	356.51
200	90	285	50	35	200	3.0	3.0	55.0	388.63
200	110	255	50	40	165	3.0	3.0	45.0	392.91
200	125	230	50	40	140	3.0	3.0	37.5	398.26
200	140	205	50	40	115	3.0	3.0	30.0	411.11
200	160	170	50	40	80	3.0	3.0	20.0	281.57
200	180	145	50	50	45	3.0	3.0	10.0	296.56
225	50	388	50	35	303	3.0	3.0	87.5	*
225	63	366	50	35	281	3.0	3.0	81.0	*
225	70	345	50	35	260	3.0	3.0	75.0	*
225	90	330	50	35	245	3.5	3.0	67.5	388.63
225	110	300	50	40	210	3.5	3.0	57.5	392.91
225	125	275	50	40	185	3.5	3.0	50.0	404.69
225	140	245	50	40	155	3.5	3.0	42.5	411.11
225	160	215	50	40	125	3.5	3.0	32.5	296.56
225	180	190	50	50	90	3.5	3.0	22.5	430.38
225	200	155	50	50	55	3.5	3.0	12.5	327.60

* prijs op aanvraag / prix sur demande / price on request

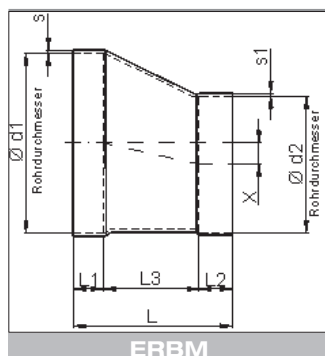
 EXCENTRISCHE REDUKTIES
 REDUCTIONS EXCENTRIQUES
 EXCENTRIC REDUCERS

d1	d2	L	L1	L2	L3	S	S1	X	€/ST/PC
250	50	431	50	35	346	3.0	3.0	100.0	-
250	63	409	50	35	324	3.0	3.0	87.5	-
250	75	388	50	35	303	3.0	3.0	93.5	-
250	90	370	50	35	285	3.5	3.0	80.0	388.63
250	110	340	50	40	250	3.5	3.0	70.0	405.78
250	125	315	50	40	225	3.5	3.0	62.5	411.11
250	140	290	50	40	200	3.5	3.0	55.0	411.11
250	160	255	50	40	165	3.5	3.0	45.0	328.67
250	180	230	50	50	130	3.5	3.0	35.0	361.86
250	200	195	50	50	95	3.5	3.0	25.0	372.57
250	225	155	50	50	55	3.5	3.5	12.5	398.26
280	110	395	50	40	305	4.0	3.0	85.0	518.17
280	125	370	50	40	280	4.0	3.0	77.5	523.52
280	140	340	50	40	250	4.0	3.0	70.0	526.74
280	160	310	50	40	220	4.0	3.0	60.0	544.94
280	180	275	50	40	185	4.0	3.0	50.0	548.15
280	200	250	50	50	150	4.0	3.0	40.0	553.50
280	225	205	50	50	105	4.0	3.5	27.5	571.70
280	250	160	50	50	60	4.0	3.5	15.0	437.88
315	110	455	50	40	375	5.0	3.0	100.0	571.70
315	125	430	50	40	340	5.0	3.0	95.0	586.69
315	140	405	50	40	315	5.0	3.0	87.5	608.10
315	160	370	50	40	280	5.0	3.0	77.5	613.45
315	180	335	50	40	245	5.0	3.0	67.5	652.00
315	200	310	50	50	210	5.0	3.0	57.5	518.17
315	225	265	50	50	165	5.0	3.5	45.0	586.69
315	250	225	50	50	125	5.0	3.5	32.5	452.86
315	280	170	50	50	70	5.0	4.0	17.5	539.58
355	160	440	50	40	350	5.0	3.0	97.5	706.60
355	180	405	50	40	315	5.0	3.0	87.5	728.01
355	200	380	50	50	280	5.0	3.0	77.5	586.69
355	225	335	50	50	235	5.0	3.5	65.0	618.81
355	250	290	50	50	190	5.0	3.5	52.5	484.98
355	280	240	50	50	140	5.0	4.0	37.5	684.11
355	315	180	50	50	80	5.0	5.0	20.0	553.50
400	160	525	60	40	425	6.0	3.0	120.0	787.96
400	180	490	60	40	390	6.0	3.0	110.0	824.36
400	200	465	60	50	355	6.0	3.0	100.0	826.50
400	225	425	60	50	315	6.0	3.5	87.5	832.93
400	250	380	60	50	270	6.0	3.5	75.0	840.42
400	280	330	60	50	220	6.0	4.0	60.0	851.13
400	315	270	60	50	160	6.0	5.0	42.5	695.89
400	355	200	60	50	90	6.0	5.0	22.5	626.30

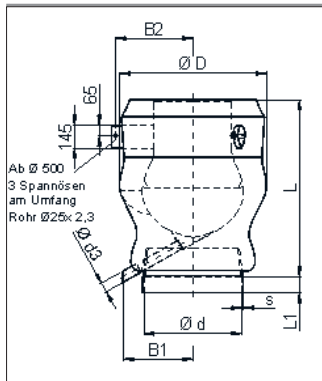

DEFL - AUG 10/N

DEFLEKTORKAPPEN
CAPOTS A DEFLECTEUR
DEFLECTION CAPS

Met lijmmoffen, op aanvraag flensaansluiting
Avec manchon, sur demande avec bride
With socket end, on request with flange

d	D	L	L1	s	B1	B2	d3	KG/ST/PC	€/ST/PC
110	170	240	40	3	80	-	16	0.5	1118.78
125	185	265	40	3	90	-	20	0.6	1250.46
140	200	295	40	3	100	-	20	1.1	1421.76
160	230	335	40	3	115	-	25	1.3	1605.90
180	250	365	50	3	130	-	25	1.5	1742.94
200	270	385	50	3	150	-	25	2.2	1830.73
225	295	450	50	3	156	-	25	2.5	2037.35
250	320	495	60	3	185	-	25	3.3	2141.95
280	360	550	50	3	205	-	25	3.7	2536.25
315	395	620	50	3	235	-	32	5.5	2721.47
355	435	690	50	4	260	-	32	6.2	*
400	595	720	70	4	290	-	40	9.0	3173.30
450	595	720	65	4	290	-	40	9.5	3220.33
500	760	920	100	6	370	410	50	13.5	3784.74

Andere diameters: op aanvraag / Autres diamètres : sur demande / Other diameters on request

Drukval bij 10 m/sec./ Pression à 10 m/sec. / Pressure drop at 10 m/sec. : **94 pa**

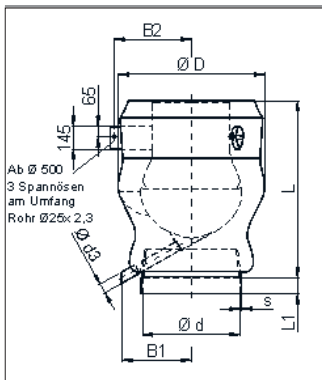

DEFL - AUG 10/BYPASS

DEFLEKTORKAPPEN
CAPOTS A DEFLECTEUR
DEFLECTION CAPS

Met lijmmoffen, op aanvraag flensaansluiting
Avec manchon, sur demande avec bride
With socket end, on request with flange

d	D	L	L1	s	B1	B2	d3	KG/ST/PC	€/ST/PC
110	170	240	40	3	80	-	20	0.5	1215.13
125	185	265	40	3	90	-	20	0.6	1321.12
140	200	295	40	3	100	-	20	1.1	1494.56
160	230	335	40	3	115	-	25	1.3	1690.48
180	250	365	50	3	130	-	25	1.5	1830.73
200	270	385	50	3	150	-	25	2.2	1943.14
225	295	450	50	3	156	-	25	2.5	2156.19
250	320	495	60	3	185	-	25	3.3	2308.21
280	360	550	50	3	205	-	25	3.7	2693.63
315	395	620	50	3	235	-	32	5.5	2867.07
355	435	690	50	4	260	-	32	6.2	2972.75
400	595	720	70	4	290	-	40	9.0	*
450	595	720	65	4	290	-	40	9.5	*
500	760	920	100	6	370	410	50	13.5	*

Andere diameters: op aanvraag / Autres diamètres : sur demande / Other diameters on request

Drukval bij 10 m/sec./ Pression à 10 m/sec. / Pressure drop at 10 m/sec. : **94 pa**

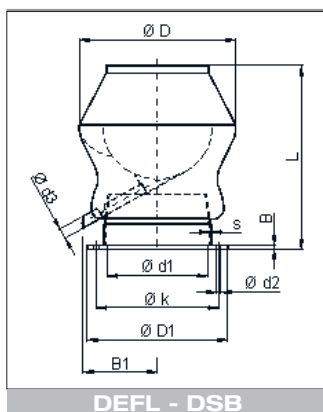

DEFL - DSB

DEFLEKTORKAPPEN
CAPOTS A DEFLECTEUR
DEFLECTION CAPS

Met lijmmoffen, op aanvraag flensaansluiting
Avec manchon, sur demande avec bride
With socket end, on request with flange

d	D	L	L1	s	B1	B2	d3	KG/STPC	€/ST/PC
110	170	215	40	3	80	-	20	0.5	806.16
125	185	240	40	3	90	-	20	0.6	820.08
140	200	260	40	3	100	-	20	0.6	952.83
160	230	290	40	3	115	-	25	0.8	1005.29
180	250	310	50	3	130	-	25	1.5	1143.40
200	270	340	50	3	150	-	25	1.7	1187.30
225	295	385	50	3	156	-	25	2.5	1438.89
250	320	420	50	3	185	-	25	2.7	1482.78
280	360	465	50	3	205	-	25	3.0	1643.37
315	395	515	50	3	235	-	32	4.6	1800.75
355	435	575	50	4	260	-	32	6.3	1992.39
400	480	635	60	4	290	-	40	7.3	2356.39

Andere diameters: op aanvraag / Autres diamètres : sur demande / Other diameters on request

Drukval bij 10 m/sec./ Pression à 10 m/sec. / Pressure drop at 10 m/sec. : **132 pa**

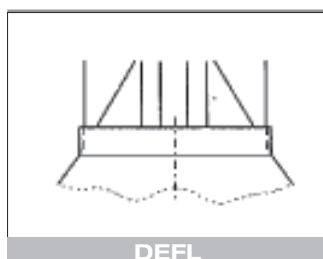

DEFL

VOGELVERSCHRIKKER
PROTECTION OISEAU
BIRD PROTECTION

d 110 - 315: **62.09 €/ST/PC**
d 355 - 630: **156.31 €/ST/PC**

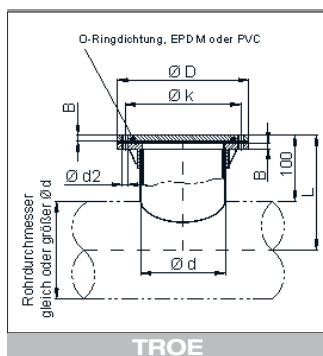

TROE

REINIGINGSOPENING
ORIFICE DE NETTOYAGE
CLEANING EYE

d	d1	L	L1	L2	s	H	D	B	K	d2	n	€/ST/PC
110	110	225	40	145	3.0	100	170	8	150	7	4	317.97
125	125	285	50	185	3.0	105	185	8	165	7	8	352.23
140	140	295	45	205	3.0	115	200	8	175	7	8	385.42
160	160	330	40	250	4.5	125	230	8	200	7	8	399.33
180	180	380	55	270	3.2	135	250	8	220	7	8	452.86
200	200	385	50	285	5.0	145	270	8	240	7	8	468.92
225	225	455	60	335	3.5	155	295	8	265	7	8	529.95
250	250	415	50	315	5.0	170	320	8	290	7	12	544.94
280	250	460	50	360	3.2	185	320	8	290	7	12	608.10
315	250	525	55	415	3.2	200	320	8	290	7	12	*
355	250	560	50	460	5.0	220	320	8	290	7	12	*
400	250	610	60	490	4.0	245	320	8	290	7	12	1014.98

n = aantal gaten / nombre de trous / number of holes

Opmerking: De bouten voor het deksel zijn niet inbegrepen.
Remarque: Les boulons de fixation du couvercle ne sont pas inclus.
Remark: The bolts for the cover are not included.